

Prosafe

Hydraulic Self Closing Gate

INSTALLATION & MAINTENANCE MANUAL

General Installation

Standard gate dimensions

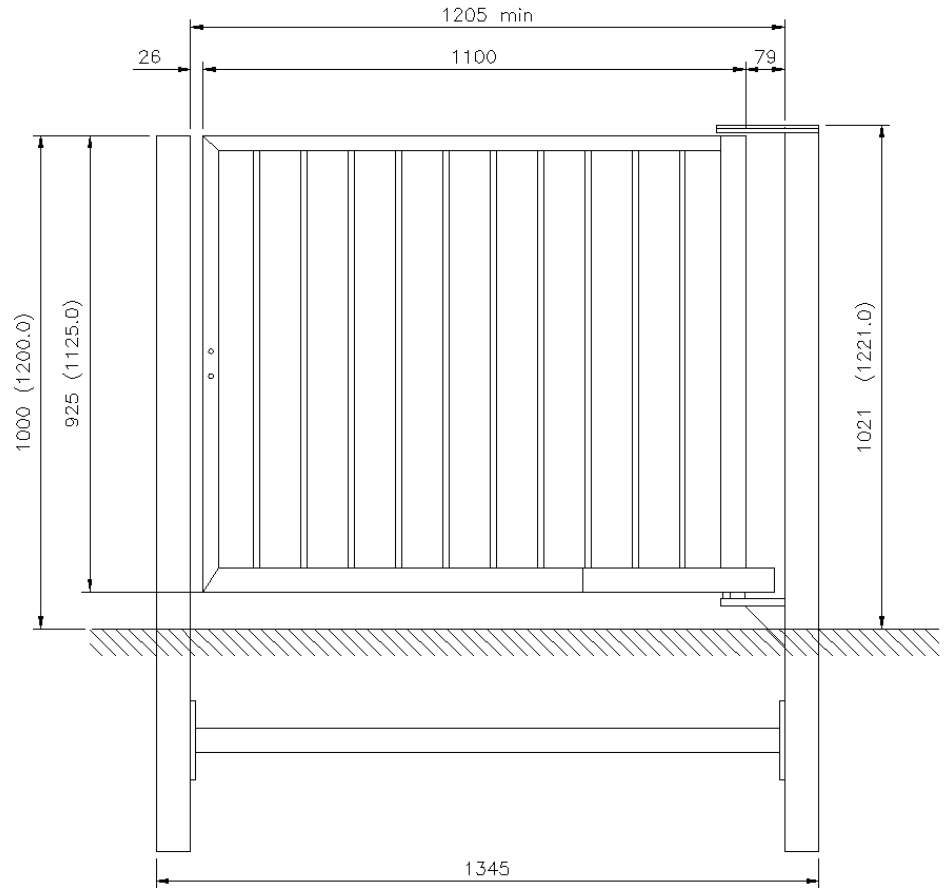

Installation

Ensure that the gate posts are set vertical and that the closing gap not less than 25mm.

It is important to settle the mechanism. Allow at least 1 hour after installation before the first operation. The gate should now be operated to check the speed.

If the gate operation does not meet the site requirements it can be adjusted as below.

Speed Adjustment

Turn both screws in a clockwise direction to close off both valves. The gate will now not close or open.

Turn both screws approx 1.5 to 1.75 turn in an anti-clockwise direction. This should give an even speed.

Fine adjustment can be made turning the screws as shown.

DO NOT TURN SCREWS MORE THAN 3 TURNS FROM THE CLOSED POSITION.

OIL LOSS MAY RESULT CAUSING THE MECHANISM TO FAIL THUS INVALIDATING ALL WARRANTIES.

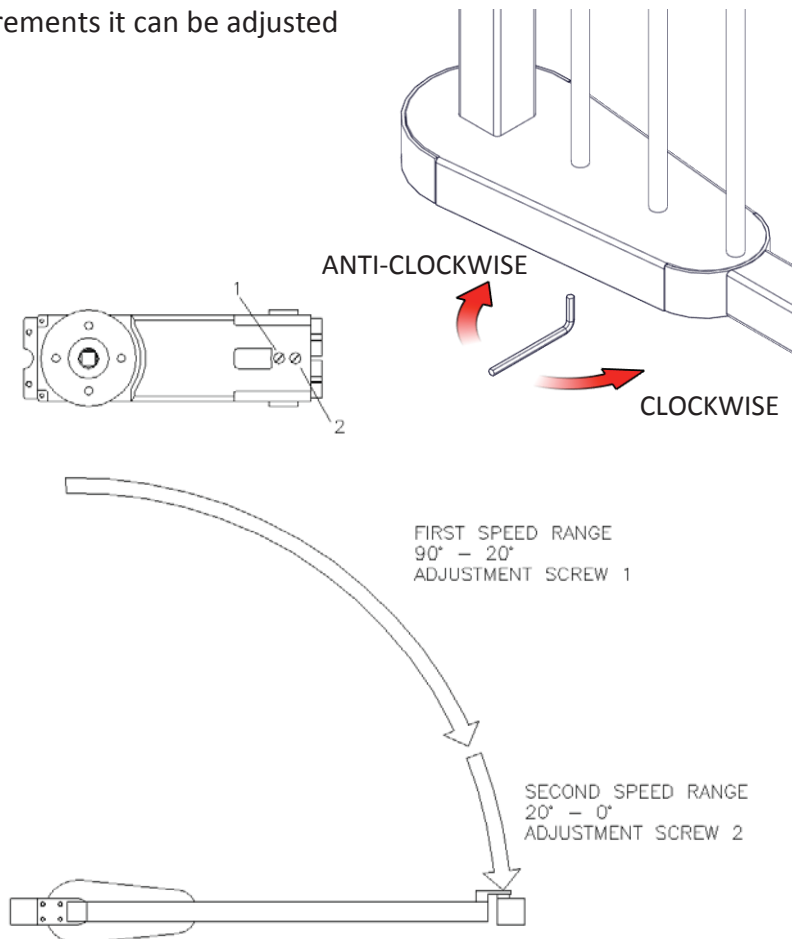

Maintenance

Bi-annual inspection:-

Check speed: Open gate to 90° and allow to close. If speed needs adjusting, refer to the instructions on page 1.

Check bottom mounting block:

Check M8 setscrews and tighten if necessary.
Check M6 cap screws and tighten if necessary.
Check all fixings and bump stop.

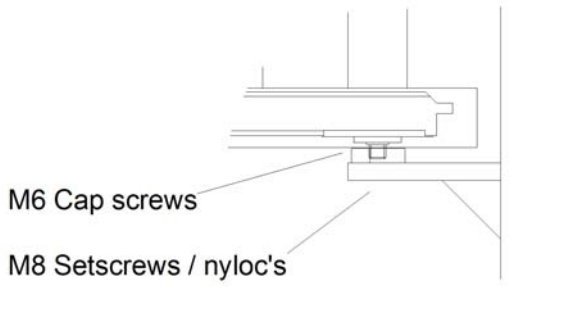

Changing the hand of the gate

All gates are supplied left hand hung or right hand hung according to customer specification. If the site

1. Remove the slam plate

The slam plate is attached by permacone nuts which are enclosed within the slam plate. To remove, either carefully remove the head of the cup sq bolt or loosen the permacone nut.

2. Remove gate

Loosen off the M6 cap screws at the base of the gate, then remove the top bracket. The top brackets are fixed together using M6 cup sq bolts and permacone nuts. To remove, chisel off the permacone nuts and then lift the gate away from the post.

3. Change the hand

The bottom mounting bracket is now accessible. To change the hand of the gate, remove the 3 no fixing M8 setscrews and turn over the mounting bracket. For earlier models, loosen the M8 nylon and rotate the mounting bracket in the other direction. Re-fix the mounting bracket securely.

4. Remount the gate

The gate needs to be mounted in the reverse order. Mount the gate into the bottom fixing bracket and replace the top bracket. Tighten the M6 cap screws and then replace the M6 cup sq bolts and permacone nuts. Check the closing speed and adjust if necessary. The gate should stop slightly past the centre of the slam post. Refit the slam plate using M8 cup sq bolt and permacone nuts.

