

PARTS LIST

ITEM	QTY	PART NUMBER	DESCRIPTION	STOCK NUMBER
1	3	TB-200-348	2150mm x 125mm SAFALOG	COMTIMSAF0001
2	2	TB-200-517_B	1700MM X 125MM (POST INSERT)	COMTIMSAF0001
3	2	TB-200-518_B	310MM X 125MM (POST INSERT)	COMTIMSAF0001
4	1	TB-200-519_B	1200MM X 125MM (POST INSERT)	COMTIMSAF0001
5	1	MOD-600-010 - LINK DUAL ROPE	LINK DUAL ROPE	
6	3	MOD-600-121 GROUND FOOT (125)	GROUND FOOT (125)	SUBSTEMIS0006
7	2	ART. 1500 1000 GROUND POST	GROUND SHOE	COMSTEMIS0020
8	2	M12 X 90 COACH BOLT	M12 X 90 (DIN 603)	COMA2CBM12X90
9	6	M12 X 240 COACH BOLT	M12 x 240 (DIN 603)	COMA2CBM12X240
10	8	M12 WASHER	M12 WASHER (DIN 125)	COMA2FWM12
11	8	M12 NYLOC NUT	M12 NYLOC NUT (DIN 985)	COMA2NNM12
12	8	30MM BOLT COVER	30MM BLACK CAP	COMPLACAP0001
13	2	300 x 300 x 400	0.036M ³ CONCRETE FOUNDATION	
14	3	400 x 400 x 500	0.08 ³ CONCRETE FOUNDATION	

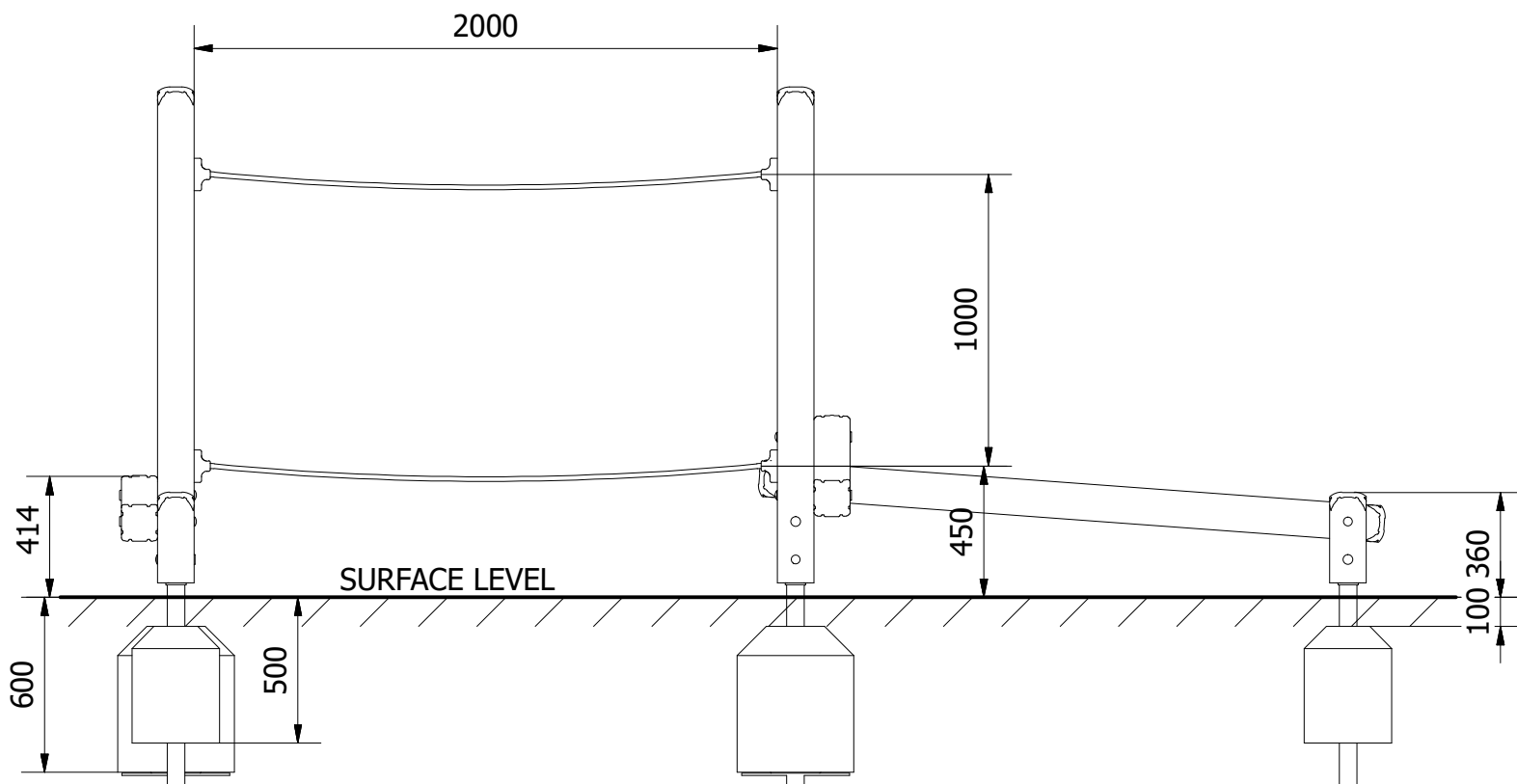
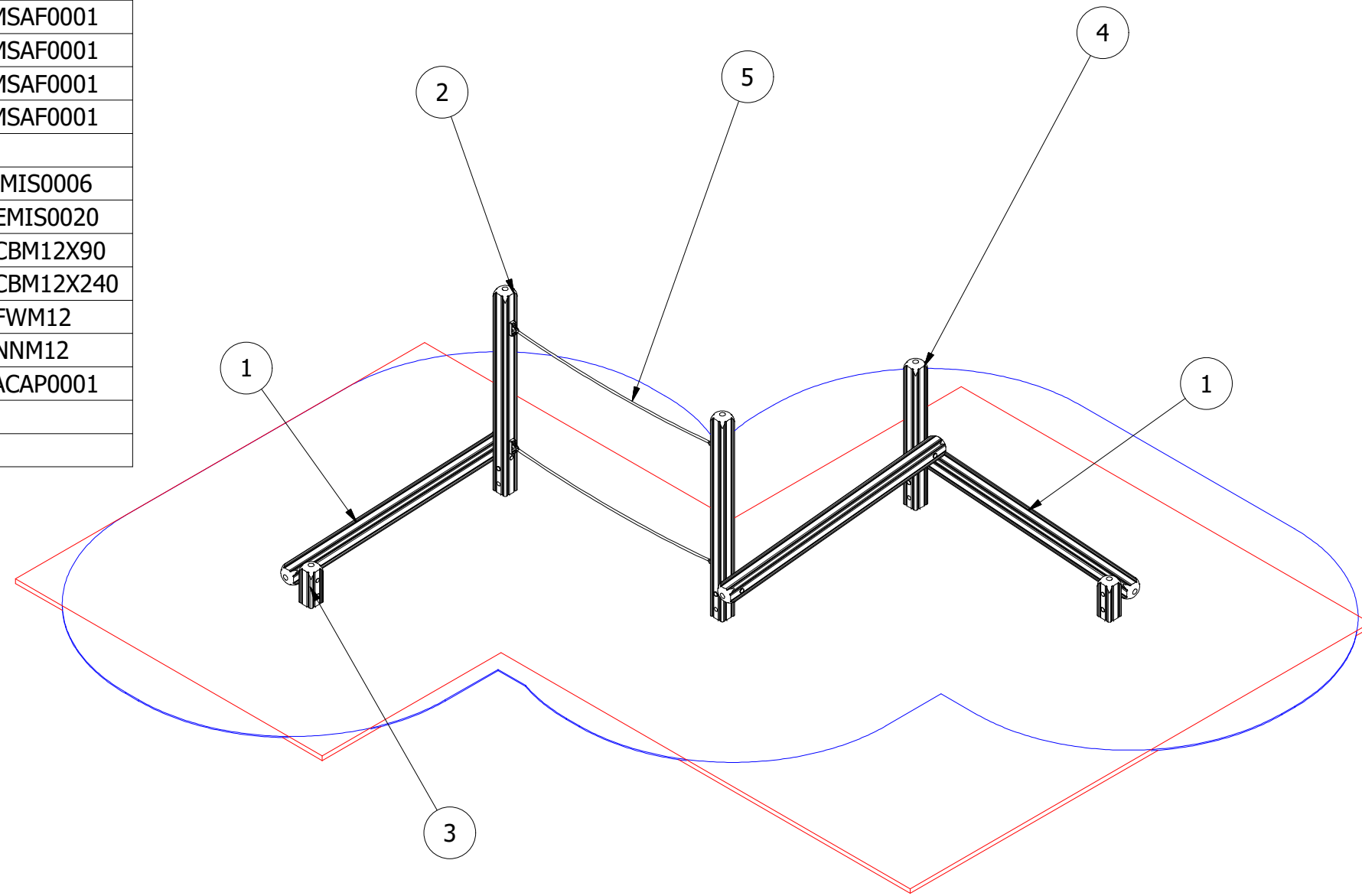

UNLESS OTHERWISE SPECIFIED:
DIMENSIONS ARE IN MILLIMETERS
TOLERANCES:
LINEAR: ±2MM
1 DECIMAL PLACE: ±0.5MM
ANGULAR: ±1°

PROPRIETARY AND CONFIDENTIAL

THE INFORMATION CONTAINED IN THIS DRAWING IS THE SOLE PROPERTY OF FENLAND LEISURE PRODUCTS. ANY REPRODUCTION IN PART OR AS A WHOLE WITHOUT THE WRITTEN PERMISSION OF FENLAND LEISURE PRODUCTS IS PROHIBITED.

Title: PRO-500-107 BALANCE COMBO (AT3)_SF

Product Range: FITNESS TRAIL

<0.6M FFH

Date:
04/10/2021

Page:

A3



DO NOT SCALE FROM DRAWING

Tel: 01354 638359 www.onlineplaygrounds.co.uk

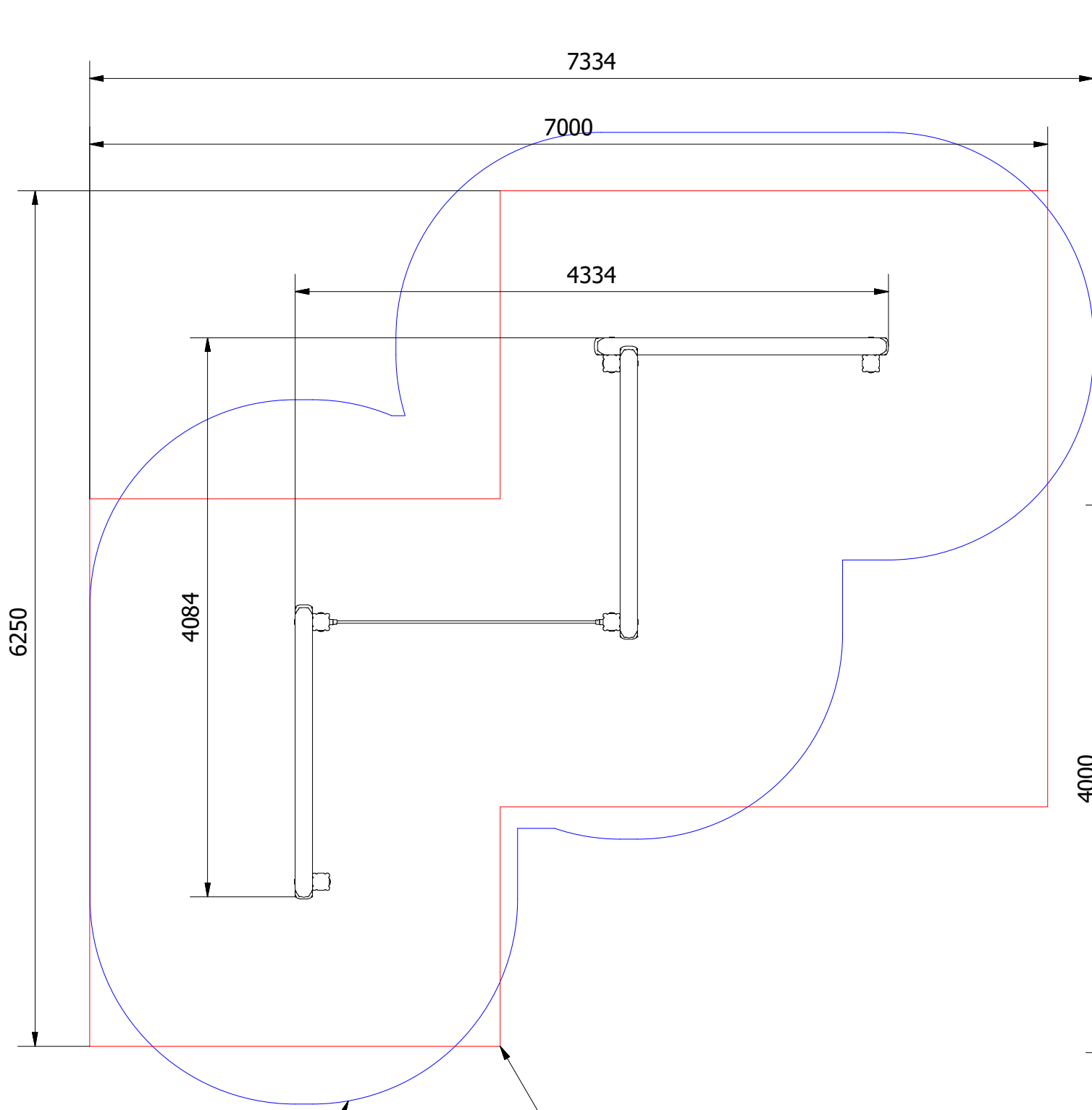

WETPOUR AREA = 30.0M²
 PERIMETER = 26.5 L/M

MIN SPACE

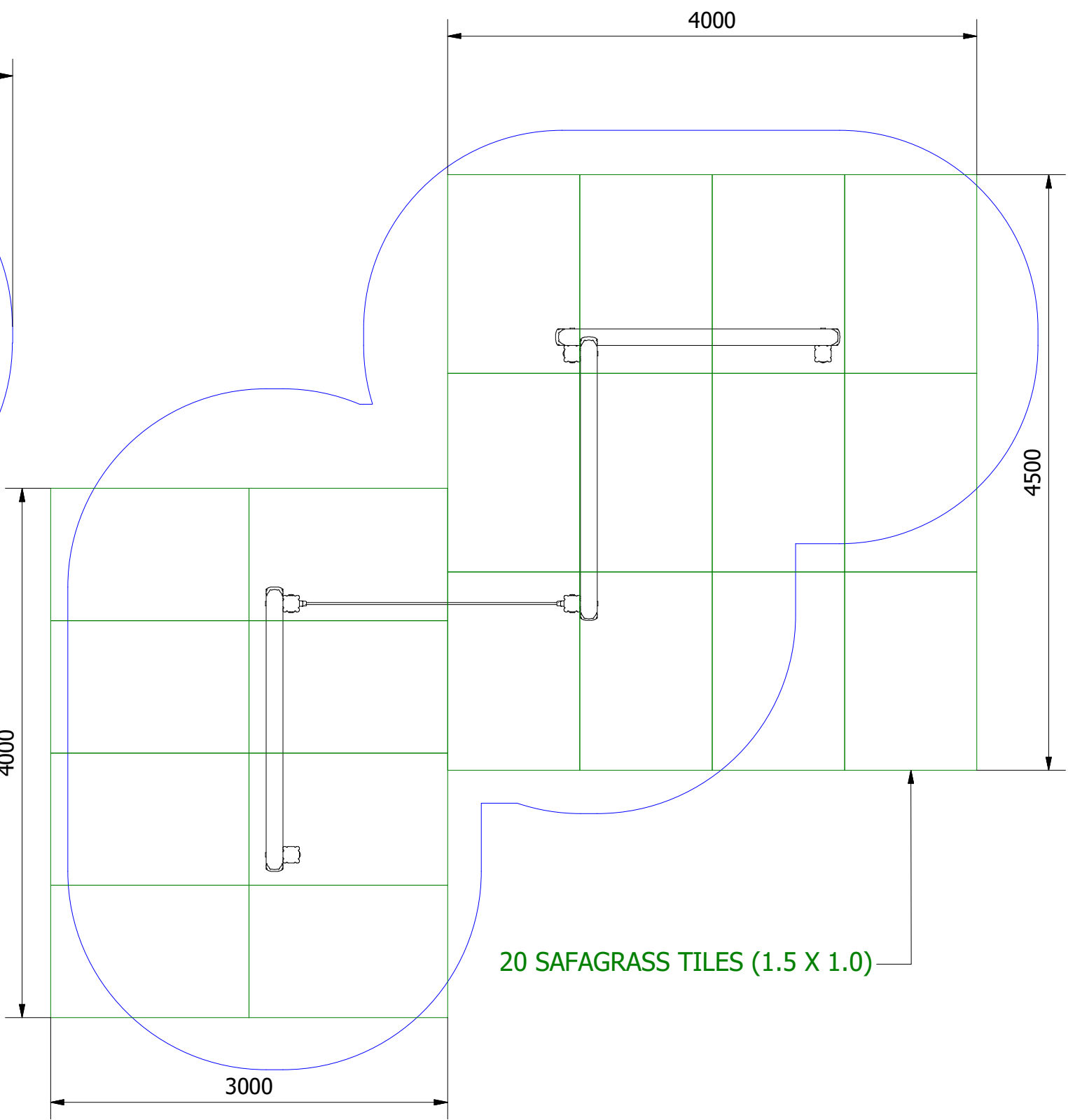

20 SAFAGRASS TILES (1.5 X 1.0)

UNLESS OTHERWISE SPECIFIED: DIMENSIONS ARE IN MILLIMETERS TOLERANCES: LINEAR: ±2MM 1 DECIMAL PLACE: ±0.5MM ANGULAR: ±1°	PROPRIETARY AND CONFIDENTIAL THE INFORMATION CONTAINED IN THIS DRAWING IS THE SOLE PROPERTY OF FENLAND LEISURE PRODUCTS. ANY REPRODUCTION IN PART OR AS A WHOLE WITHOUT THE WRITTEN PERMISSION OF FENLAND LEISURE PRODUCTS IS PROHIBITED.	Title: PRO-500-107 BALANCE COMBO (AT3)_SF	
		Product Range: FITNESS TRAIL	
		Date: 04/10/2021	
		Page: A3	
		DO NOT SCALE FROM DRAWING	
		Tel: 01354 638359 www.onlineplaygrounds.co.uk	

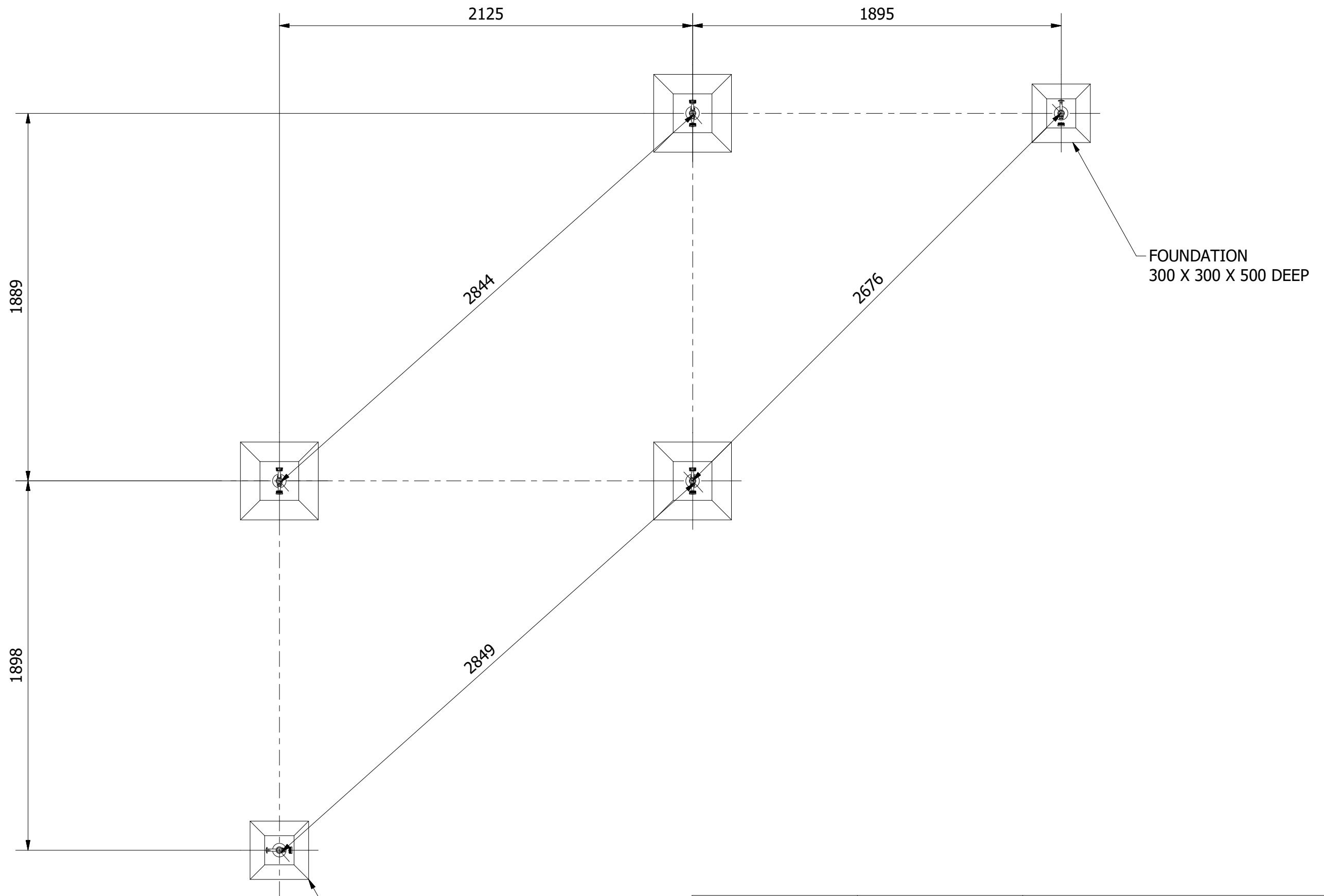

FOUNDATION
300 X 300 X 500 DEEP

FOUNDATION
300 X 300 X 500 DEEP

UNLESS OTHERWISE SPECIFIED:
DIMENSIONS ARE IN MILLIMETERS
TOLERANCES:
LINEAR: ±2MM
1 DECIMAL PLACE: ±0.5MM
ANGULAR: ±1°

PROPRIETARY AND CONFIDENTIAL
THE INFORMATION CONTAINED IN THIS
DRAWING IS THE SOLE PROPERTY OF
FENLAND LEISURE PRODUCTS. ANY
REPRODUCTION IN PART OR AS A WHOLE
WITHOUT THE WRITTEN PERMISSION
OF FENLAND
LEISURE PRODUCTS IS PROHIBITED.

Title: PRO-500-107 BALANCE COMBO (AT3)_SF

Product Range: FITNESS TRAIL

Date:
04/10/2021

Page:
A3



DO NOT SCALE FROM DRAWING

Tel: 01354 638359 www.onlineplaygrounds.co.uk

ALL FOUNDATIONS 400 X 400 X 600 DEEP UNLESS OTHERWISE SPECIFIED

1. POSITION THE UPRIGHT POSTS INTO THE FOUNDATION HOLES AS DETAILED ON THE PREVIOUS PAGE AND BRACE IN POSITION.
2. JOIN THE POSTS TOGETHER WITH THE BALANCE BEAMS AS DETAILED BELOW USING THE SUPPLIED FIXINGS.

3. WITH THE TIMBERS CONNECTED AND BRACED, SECURE THE ROPE BETWEEN THE TWO UPRIGHTS
4. FINALLY, ENSURE ALL FIXINGS HAVE BEEN TIGHTENED AND PROTECTIVE CAPS IN PLACE. ADD CONCRETE TO EACH FOUNDATION HOLE AND LEAVE FOR 48 HOURS

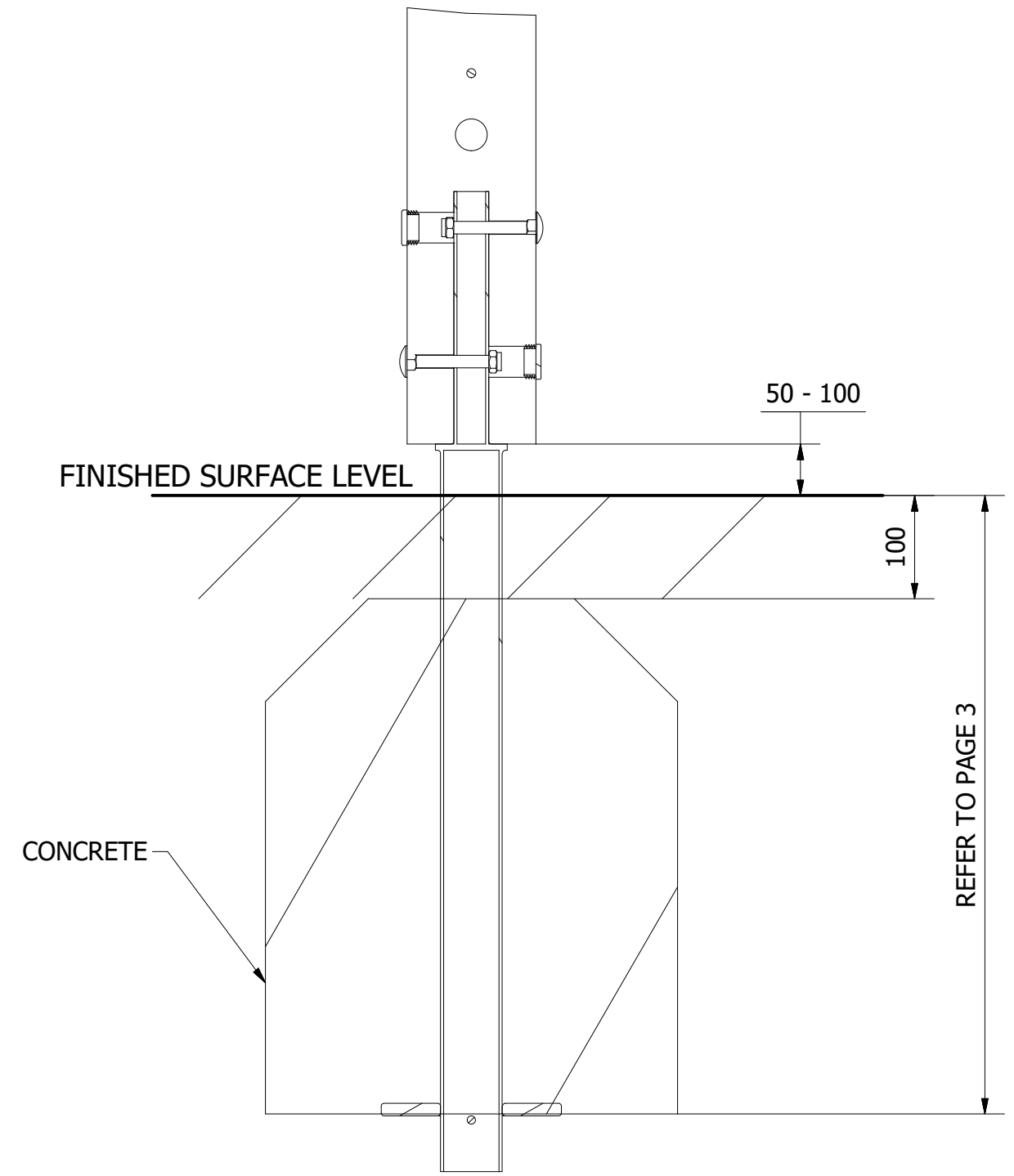
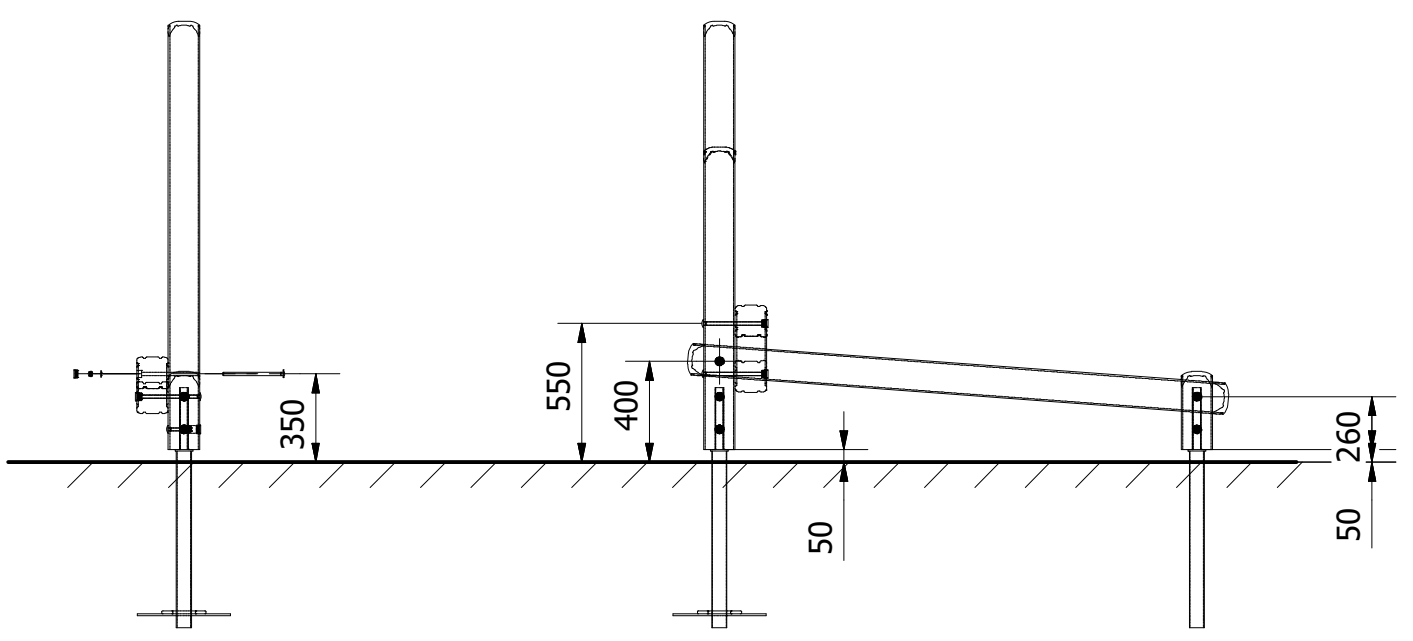
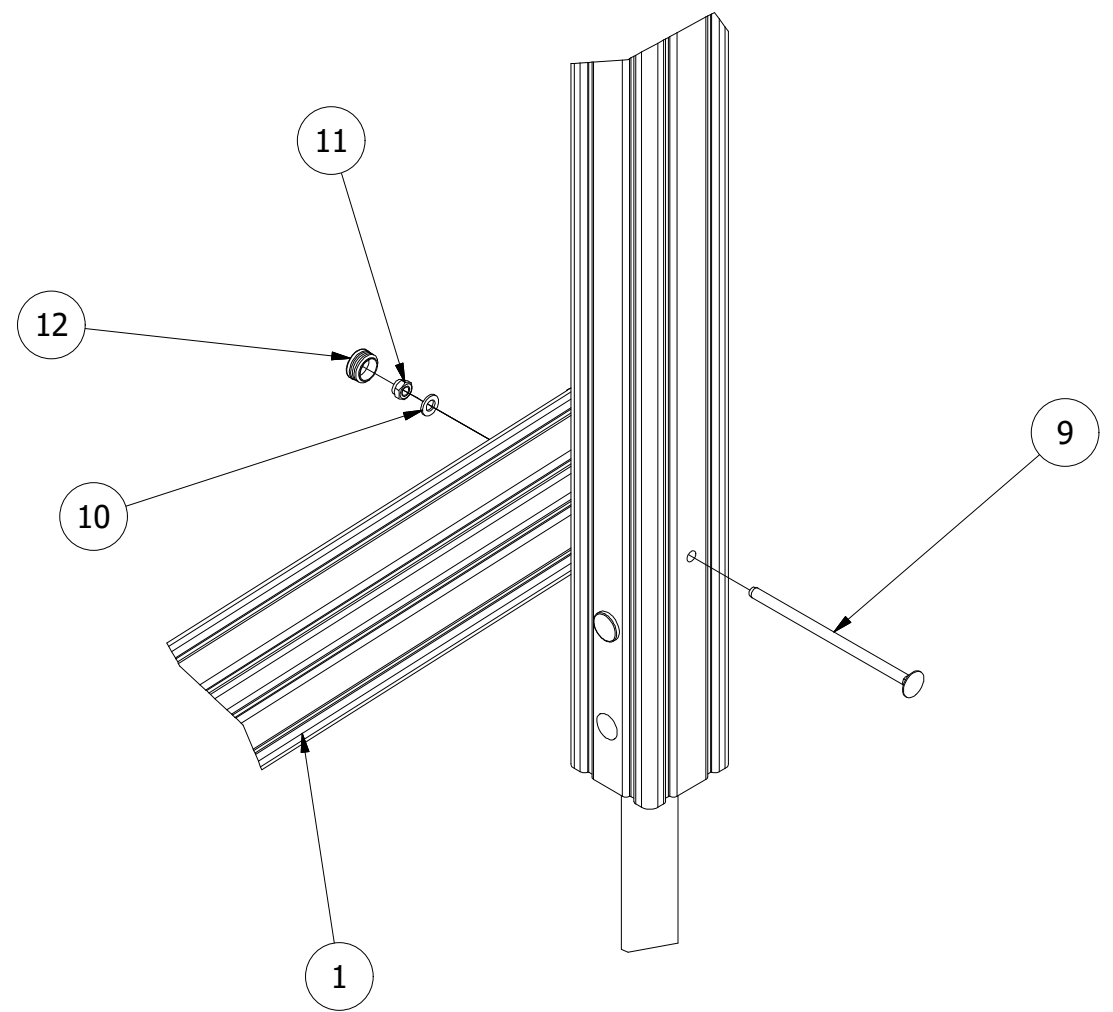

UNLESS OTHERWISE SPECIFIED: DIMENSIONS ARE IN MILLIMETERS TOLERANCES: LINEAR: ±2MM 1 DECIMAL PLACE: ±0.5MM ANGULAR: ±1°	PROPRIETARY AND CONFIDENTIAL THE INFORMATION CONTAINED IN THIS DRAWING IS THE SOLE PROPERTY OF FENLAND LEISURE PRODUCTS. ANY REPRODUCTION IN PART OR AS A WHOLE WITHOUT THE WRITTEN PERMISSION OF FENLAND LEISURE PRODUCTS IS PROHIBITED.	Title: PRO-500-107 BALANCE COMBO (AT3)_SF	
		Product Range: FITNESS TRAIL	
		Date: 04/10/2021	
		Page: A3	
		DO NOT SCALE FROM DRAWING	
Tel: 01354 638359 www.onlineplaygrounds.co.uk			